



BUILT WITH PASSION.
OWNED WITH PRIDE.

FIRE MAGIC PREMIUM OUTDOOR GRILLS COLLECTION CATALOG 2014



CRAFTED WITH PRIDE  IN THE USA

PREMIUM OUTDOOR GRILLS



For more than 75 years, Fire Magic® has been building the world's finest outdoor grills for people who demand the highest quality and performance. Our passion for manufacturing premium grills will be felt in the pride of ownership that you'll enjoy for a lifetime.

Constructed entirely of the finest quality, heavy gauge 304 stainless steel with unsurpassed attention to the most precise detail in design and construction, Fire Magic® Grills are the most elegant, and the most durable barbecues available. They easily perform at the highest temperatures for the longest time of any outdoor barbecue grill. With unique features like our advanced heating distribution system, a searing option, smoking capability, most complete rotisserie cooking, and even charcoal grilling, Fire Magic® offers a truly unmatched grilling experience.

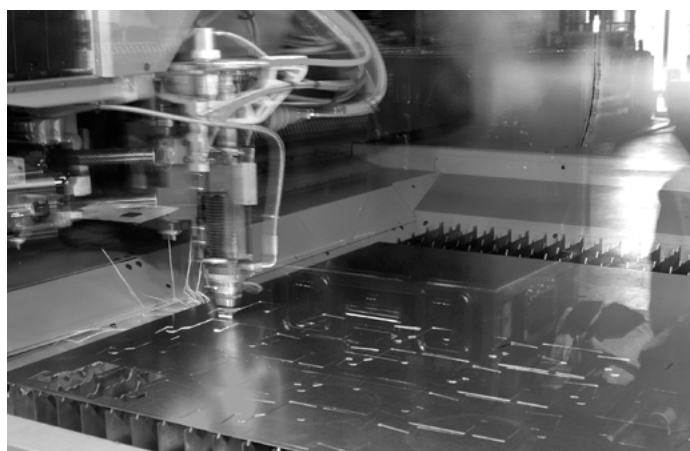

Every Fire Magic® product is manufactured in our US production facility and held to the strictest safety standards and the highest performance metrics. Using state-of-the-art technology guided by the watchful eye and careful hand of master craftsmen, our grills are an investment that pays dividends for years and years. They are engineered and built to perform for a lifetime. The pride and joy from owning your Fire Magic® Grill will last for years to come.

BUILT WITH PASSION.
OWNED WITH PRIDE.

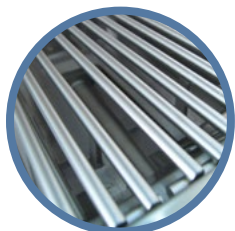

HEAVY DUTY STAINLESS STEEL COOKING GRIDS



MULTI-COLORED BACKLIT THERMOMETER

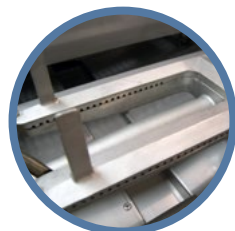

EXCLUSIVE CAST STAINLESS STEEL "E" BURNERS



OPTIONAL MAGIC VIEW WINDOW



HOT SURFACE IGNITION



COMFORT TOUCH BLUE BACKLIT KNOBS



SLEEK LINES & CONTOURED FACE



WOODCHIP SMOKER DRAWER

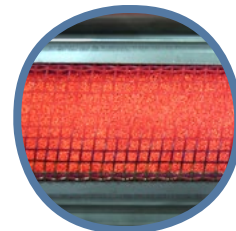

QUANTUM BACKBURNER



HALOGEN LIGHTS



ECHELON



DIAMOND SERIES

BUILT-IN & STAND ALONE GRILLS

» DISCOVER THE DIFFERENCE

- » All 304 Stainless Steel Construction
- » Cast stainless steel "E" burners for consistent, even heat distribution, guaranteed for life (optional infrared burners are available)
- » Most BTU's and heat per square inch. Heats fast and stays hot
- » Largest cooking space compared to other same sized grills
- » 16-gauge stainless steel, flavor grids are engineered for durability, even heat distribution and reduced flare-ups
- » Feather-Lite, easy-lift oven hood with spring assist
- » Meat Probe with multi functional digital thermometer read-out
- » 12" deep fire box (top to bottom). Provides the most complete convection cooking
- » Angled interior halogen lights for evening grilling
- » 22" long watertight wood chip smoker box with 3,000 BTU's dedicated burner
- » Hot surface electronic ignition - lights every time
- » Master power switch turns off electrical system when not in use
- » Recessed Quantum Backburner that uses less BTU's to generate high heat making it ideal for efficient, versatile rotisserie cooking
- » Heavy-duty rotisserie spit rod with roller ball-bearings support and super-high torque motor
- » Built-in storage brackets for rotisserie spit rod
- » Fully illuminated safety control knobs (flame turns red when on)
- » Integral, and removable, oven warming rack for light cooking or warming foods
- » Customized stainless steel name plaque to personalize your grill
- » Heat zone separators isolate cooking areas so food in each section may be grilled at different temperatures
- » Built-in grill is field convertible (natural gas/ propane gas)
- » Available in the Echelon "A" model with a simple analog thermometer in the hood encircled in a highly polished stainless steel bezel
- » Optional Magic View Window to check on food without lifting hood
- » Optional infrared burner (no additional charge)
- » Optional exclusive motorized hood

ECHELON

DIAMOND SERIES

BUILT-IN GRILLS



MODEL: E1060i-4E1N*-W

COOKING SURFACE Primary: 1056 sq. in. [48" x 22"] Secondary: 384 sq. in. [48" x 8"] **

BTU's 112,000 Primary + (2) 11,000 Backburners
+ 3,000 Dedicated Smoker Burner

CUT-OUT 50" w x 23½" d x 12" h

Model shown optional Magic View Window.



MODEL: E790i-4E1N*

COOKING SURFACE Primary: 792 sq. in. [36" x 22"] Secondary: 288 sq. in. [36" x 8"] **

BTU's 96,000 Primary + 13,000 Backburner
+ 3,000 Dedicated Smoker Burner

CUT-OUT 37" w x 23½" d x 12" h



MODEL: E660i-4E1N*

COOKING SURFACE Primary: 660 sq. in. [30" x 22"] Secondary: 240 sq. in. [30" x 8"] **

BTU's 75,000 Primary + 11,000 Backburner
+ 3,000 Dedicated Smoker Burner

CUT-OUT 31¼" w x 23½" d x 12" h

*All models available in natural gas or propane.

** The warming rack is the secondary cooking surface on the grill



MODEL: E1060i-4EAN*

COOKING SURFACE Primary: 1056 sq. in. [48" x 22"] Secondary: 384 sq. in. [48" x 8"]**

BTU's 112,000 Primary + (2) 11,000 Backburners
+ 3,000 Dedicated Smoker Burner

CUT-OUT 50" w x 23½" d x 12" h

ECHELON
 DIAMOND "A" SERIES

BUILT-IN GRILLS



MODEL: E790i-4EAN*

COOKING SURFACE Primary: 792 sq. in. [36" x 22"] Secondary: 288 sq. in. [36" x 8"]**

BTU's 96,000 Primary + 13,000 Backburner
+ 3,000 Dedicated Smoker Burner

CUT-OUT 37" w x 23½" d x 12" h



MODEL: E660i-4EAN*

COOKING SURFACE Primary: 660 sq. in. [30" x 22"] Secondary: 240 sq. in. [30" x 8"]**

BTU's 75,000 Primary + 11,000 Backburner
+ 3,000 Dedicated Smoker Burner

CUT-OUT 31¼" w x 23½" d x 12" h

*All models available in natural gas or propane.

** The warming rack is the secondary cooking surface on the grill

ECHELON

DIAMOND SERIES

STAND ALONE GRILLS



MODEL: E1060s-4E1N*-51-W

COOKING SURFACE Primary: 1056 sq. in. [48" x 22"] Secondary: 384 sq. in. [48" x 8"]**

BTU's 112,000 Primary + (2) 11,000 Backburners
+ 3,000 Dedicated Smoker Burner + 60,000 Power Burner

Model shown with Power Burner & optional Magic View Window. Also available with a Double Side Burner (-71) or Single Side Burner option (-62).



MODEL: E790s-4E1N*-71

COOKING SURFACE Primary: 792 sq. in. [36" x 22"] Secondary: 288 sq. in. [36" x 8"]**

BTU's 96,000 Primary + 13,000 Backburners
+ 3,000 Dedicated Smoker Burner + 30,000 Double Side Burner

Model shown with Double Side Burner. Also available with a Single Side Burner Option (-62).



MODEL: E660s-4E1N*-62

COOKING SURFACE Primary: 660 sq. in. [30" x 22"] Secondary: 240 sq. in. [30" x 8"]**

BTU's 75,000 Primary + 11,000 Backburners
+ 3,000 Dedicated Smoker Burner + 15,000 Single Side Burner

Model shown with Single Side Burner. Also available with a Double Side Burner Option (-71).

*All models available in natural gas or propane (for propane change N to P).

** The warming rack is the secondary cooking surface on the grill



MODEL: E1060s-4EAN*-51

COOKING SURFACE Primary: 1056 sq. in. [48" x 22"] Secondary: 384 sq. in. [48" x 8"]**

BTU's 112,000 Primary + (2) 11,000 Backburners
+ 3,000 Dedicated Smoker Burner + 60,000 Power Burner

Model shown with Power Burner. Also available with a Double Side Burner (-71) or Single Side Burner (-62) option.

ECHELON
 DIAMOND "A" SERIES

STAND ALONE GRILLS



MODEL: E790s-4EAN*-71

COOKING SURFACE Primary: 792 sq. in. [36" x 22"] Secondary: 288 sq. in. [36" x 8"]**

BTU's 96,000 Primary + 13,000 Backburners
+ 3,000 Dedicated Smoker Burner + 30,000 Double Side Burner

Model shown with Double Side Burner. Also available with a Single Side Burner Option (-62).



MODEL: E660s-4EAN*-62

COOKING SURFACE Primary: 660 sq. in. [30" x 22"] Secondary: 240 sq. in. [30" x 8"]**

BTU's 75,000 Primary + 11,000 Backburners
+ 3,000 Dedicated Smoker Burner + 15,000 Single Side Burner

Model shown with Single Side Burner. Also available with a Double Side Burner Option (-71).

*All models available in natural gas or propane.
 ** The warming rack is the secondary cooking surface on the grill



HEAVY DUTY STAINLESS STEEL COOKING GRIDS



BUILT-IN DIGITAL THERMOMETER



EXCLUSIVE CAST STAINLESS STEEL "E" BURNERS



SPRING ASSISTED LID

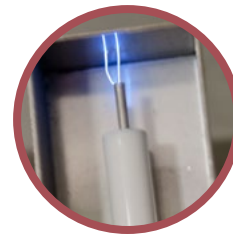

ELECTRONIC PUSH-TO-LIGHT SPARK IGNITION



COMFORT TOUCH KNOBS



BEAUTIFUL GOURMET FACE



SLEEK ON/OFF LIGHT CONTROL BUTTON



STAINLESS STEEL BACKBURNER



HALOGEN LIGHTS



AURORA

S E R I E S

BUILT-IN & STAND ALONE GRILLS

» FEATURE HIGHLIGHTS

- » All 304 Stainless Steel Construction
- » Cast stainless steel "E" burners for consistent, even heat distribution, guaranteed for life (optional infrared burners are available)
- » Most BTU's and heat per square inch. Heats fast and stays hot
- » Largest cooking space compared to other same sized grills
- » 16-gauge stainless steel, flavor grids are engineered for durability, even heat distribution and reduced flare-ups
- » Feather-Lite, easy-lift oven hood with spring assist
- » Meat Probe with digital thermometer read-out
- » 12" deep fire box (top to bottom). Provides the most complete convection cooking
- » Interior halogen lights
- » Electronic push-to-light spark ignition system (no batteries required)
- » Easy to use drip collection system
- » Optional recessed stainless steel rotisserie backburner and heavy duty rotisserie kit
- » (2) four-skewer meat holders with heavy counter balance
- » Built-in storage rack for rotisserie spit rod
- » Comfort touch heavy-duty control knobs
- » Integral and removable, oven warming rack for light cooking or warming foods
- » Sleek styling with seamless control panel
- » A grill of superior design and engineering -- crafted for cooking versatility, durability, and longevity
- » Built-in grill is convertible (natural gas/propane gas)

AURORA

S E R I E S

BUILT-IN GRILLS



All Aurora grills now include interior halogen lights



MODEL: A830i-2E1N*-CB

	<input type="checkbox"/> GAS	<input type="checkbox"/> CHARCOAL	<input type="checkbox"/> GAS	<input type="checkbox"/> CHARCOAL
COOKING SURFACE	Primary: 828 sq. in. [24" x 18" + 22" x 18"]		Secondary: 368 sq. in. [24" x 8" + 22" x 8"]**	
BTU's	50,000 Primary + 13,000 Backburner + 26,000 Charcoal Ignitor			
CUTOUT	50 1/2" w x 19 1/2" d x 12" h			

A830i lights are on the gas side of the grill only



MODEL: A790i-2E1N*

COOKING SURFACE	Primary: 792 sq. in. [36" x 22"]	Secondary: 288 sq. in. [36" x 8"]**
BTU's	90,000 Primary + 20,000 Backburner	
CUT-OUT	37 3/4" w x 23 1/2" d x 12" h	

*All models available in natural gas or propane. // All models (except A790) also available without backburner & rotisserie. Change the 6th digit to a "1"

** The warming rack is the secondary cooking surface on the grill



MODEL: A660i-2E1N*

COOKING SURFACE	Primary: 660sq. in. [30" x 22"] Secondary: 240sq. in. [30" x 8"]**
BTU's	75,000 Primary + 18,000 Backburner
CUT-OUT	32" w x 23½" d x 12" h



MODEL: A540i-2E1N*

COOKING SURFACE	Primary: 540sq. in. [30" x 18"] Secondary: 240sq. in. [30" x 8"]**
BTU's	60,000 Primary + 18,000 Backburner
CUT-OUT	32" w x 19½" d x 12" h

AURORA

S E R I E S

BUILT-IN GRILLS



MODEL: A530i-2E1N*

COOKING SURFACE	Primary: 528sq. in. [24" x 22"] Secondary: 192sq. in. [24" x 8"]**
BTU's	60,000 Primary + 13,000 Backburner
CUT-OUT	25½" w x 23½" d x 12" h



MODEL: A430i-2E1N*

COOKING SURFACE	Primary: 432sq. in. [24" x 18"] Secondary: 192sq. in. [24" x 8"]**
BTU's	50,000 Primary + 13,000 Backburner
CUT-OUT	25½" w x 19½" d x 12" h

*All models available in natural gas or propane. // All models (except A790) also available without backburner & rotisserie. Change the 6th digit to a "1"

** The warming rack is the secondary cooking surface on the grill

AURORA

S E R I E S

STAND ALONE GRILLS



All Aurora grills now include interior halogen lights



MODEL: A830i-2E1N*-CB

COOKING SURFACE	GAS		CHARCOAL	
	Primary	Secondary	Primary	Secondary
	828 sq. in. [24" x 18" + 22" x 18"]	368 sq. in. [24" x 8" + 22" x 8"]**		

BTU's 50,000 Primary + 13,000 Backburner + 26,000 Charcoal Ignitor

A830i lights are on the gas side of the grill only



MODEL: A660i-2E1N*-62

COOKING SURFACE Primary: 660 sq. in. [30" x 22"] Secondary: 240 sq. in. [30" x 8"]**

BTU's 75,000 Primary + 18,000 Backburner + 15,000 Single Side Burner

*All models available in natural gas or propane. // All models also available without backburner & rotisserie. Change the 6th digit to a "1"

** The warming rack is the secondary cooking surface on the grill



MODEL: A540i-2E1N*-62

COOKING SURFACE Primary: 540 sq. in. [30" x 18"] Secondary: 240 sq. in. [30" x 8"]**
 BTU's 60,000 Primary + 18,000 Backburner + 15,000 Single Side Burner



MODEL: A530i-2E1N*-62

COOKING SURFACE Primary: 528 sq. in. [24" x 22"] Secondary: 192 sq. in. [24" x 8"]**
 BTU's 60,000 Primary + 13,000 Backburner + 15,000 Single Side Burner

AURORA

S E R I E S

STAND ALONE GRILLS



MODEL: A430s-2E1N*-62

COOKING SURFACE Primary: 432 sq. in. [24" x 18"] Secondary: 192 sq. in. [24" x 8"]**
 BTU's 50,000 Primary + 13,000 Backburner + 15,000 Single Side Burner



MODEL: 5110-32
 Optional stainless steel
 LP tank shield

MODEL: A430s-2E1N*-P6

COOKING SURFACE Primary: 432 sq. in. [24" x 18"] Secondary: Primary: 192 sq. in. [24" x 8"]**
 BTU's 50,000 Primary + 13,000 Backburner

Includes timer on post. Also available as an in-ground post model. (Change "P6" to "G6")

*All models available in natural gas or propane. // All models also available without backburner & rotisserie. Change the 6th digit to a "1"

** The warming rack is the secondary cooking surface on the grill



CHOICE

BUILT-IN
& STAND ALONE GRILLS



MODEL: C540i-1T1N*

COOKING SURFACE	Primary: 540 sq. in. [30" x 18"] Secondary: 240 sq. in. [30" x 8"]**
BTU's	60,000 Primary
CUT-OUT	32" w x 19½" d x 12" h

CHOICE GRILL

Fire Magic® introduces the all new Choice Grill. The Choice Grill is constructed of all 304 stainless steel and features heavy gauge tubular stainless steel burners, an analog thermometer, a 9 volt electronic ignition, all stainless steel cooking grids, and a stainless steel manifold complete with brass valves. These great features are housed in a beautiful Aurora style grill with a simple satin stainless steel face plate.



MODEL: C430i-1T1N*

COOKING SURFACE	Primary: 432 sq. in. [24" x 18"] Secondary: 432 sq. in. [24" x 8"]**
BTU's	40,000 Primary
CUT-OUT	25½" w x 19½" d x 12" h

*All models available in natural gas or propane.
** The warming rack is the secondary cooking surface on the grill

CHOICE

BUILT-IN &
STAND ALONE GRILLS



MODEL: C540s-1T1N*-96

COOKING SURFACE Primary: 540 sq. in. [30" x 18"] Secondary: 240 sq. in. [30" x 8"]**

BTU's 60,000 Primary



MODEL: C430s-1T1N*-96

COOKING SURFACE Primary: 432 sq. in. [24" x 18"] Secondary: 192 sq. in. [24" x 8"]**

BTU's 40,000 Primary

*All models available in natural gas or propane.
** The warming rack is the secondary cooking surface on the grill



LEGACY

ELECTRIC, DELUXE,
& COUNTERTOP GRILLS

ELECTRIC GRILLS

The Fire Magic® Electric Grill provides quick, clean, and easy grilling. Great for patios with limited space, or where gas fuel is unavailable.

- All 304 stainless steel construction (housing)
- Heats up to 800° F (1800 watt grill)
- 252 sq. inches of grilling space
- Stainless steel cooking grids
- 120 volt. Just plug in and use
- Digital thermometer with thermostatic control and meat probe for precision grilling
- Double walled oven lid
- Easy to clean drip tray



MODEL: E250t-1Z1E

COOKING SURFACE 252 sq. inches [15 ½" x 16 ¼"]



MODEL: E250S-1Z1E-P6

COOKING SURFACE 252 sq. inches [15 ½" x 16 ¼"]

Patio Post Model

DELUXE GRILLS



MODEL: 11-S1S1N*-A

COOKING SURFACE	368 sq. inches [23" x 16"]
BTU's	42,000 Primary
CUT-OUT	24 ¾" w x 17 ¾" d x 12" h

- Heavy-duty stainless steel construction
- Optional infrared burner



PATIO POST
MODEL: 21-S1S1N*-P6

MODEL: 5110-32
Optional stainless steel
LP tank shield

Includes timer on post. Also available as an in-ground post model. (Change "P6" to "G6")

LEGACY

ELECTRIC, DELUXE,
& COUNTERTOP GRILLS

COUNTERTOP GRILLS



MODEL: 3C-S1S1N*-A (pictured)

COOKING SURFACE	368 sq. inches [23" x 16"]
BTU's	42,000 Primary
CUT-OUT	29½" w x 16½" d x 14" h

MODEL: 34-S2S1N*-A

COOKING SURFACE	540 sq. inches [30" x 18"]
BTU's	66,000 Primary
CUT-OUT	41½" w x 20½" d x 18" h

Optional Rotisserie Backburner 22,000 BTU's

MODEL: 31-S1S1N*-A

COOKING SURFACE	368 sq. inches [23" x 16"]
BTU's	42,000 Primary
CUT-OUT	24½" w x 19 ¼" d x 12" h

*All models available in natural gas or propane.



CHARCOAL

CHARCOAL GRILLS & SMOKER



CHARCOAL GRILLS & SMOKER

From a commercial-grade stainless steel, high capacity smoker to a high performance charcoal grill available in a variety of models, Fire Magic® delivers quality and style to the charcoal grill and smoker enthusiast.

MODEL: 24s-SMB (pictured left)

COOKING SURFACE 1640 sq. inches
[5 grids 17 ½" x 18 ¾" each]

Model includes base storage drawer

MODEL: 24s-SM (pictured right)

COOKING SURFACE 1640 sq. inches
[5 grids 17 ½" x 18 ¾" each]





MODEL: 24-SC01C-61 (pictured)

COOKING SURFACE Primary: 540 sq. in. [30" x 18"] Secondary: 160 sq. in. [20" x 8"]

MODEL: 22-SC01C-61

COOKING SURFACE Primary: 432 sq. in. [24" x 18"] Secondary: 184 sq. in. [23" x 8"]

Classic rounded oven hood also available



MODEL: 14-SC01C-A (pictured)

COOKING SURFACE Primary: 540 sq. in. [30" x 18"] Secondary: 160 sq. in. [20" x 8"]

CUT-OUT 32 1/4" w x 19 3/4" d x 12" h

MODEL: 12-SC01C-A

COOKING SURFACE Primary: 432 sq. in. [24" x 18"] Secondary: 184 sq. in. [23" x 8"]

CUT-OUT 26 1/4" w x 19 3/4" d x 12" h

CHARCOAL

CHARCOAL GRILLS & SMOKER



FIREMASTER

MODEL: 3324*

COOKING SURFACE 540 sq. inches [30" x 18"]

CUT-OUT 31 1/4" w x 21 1/4" d x 12" h

MODEL: 3329*

COOKING SURFACE 368 sq. inches [23" x 16"]

CUT-OUT 24 1/4" w x 19 1/4" d x 12" h

- Designed to drop into the top of your island
- Adjustable charcoal pan for easy cooking control



LIFT-A-FIRE

MODEL: 3334*

COOKING SURFACE 540 sq. inches [30" x 18"]

CUT-OUT 32 1/4" w x 19 3/4" d x 12" h

MODEL: 3339*

COOKING SURFACE 368 sq. inches [23" x 16"]

CUT-OUT 24 1/4" w x 17 3/4" d x 12" h

- Constructed of heavy-duty steel with durable powder coated enamel finish
- Adjustable charcoal pan for easy cooking control

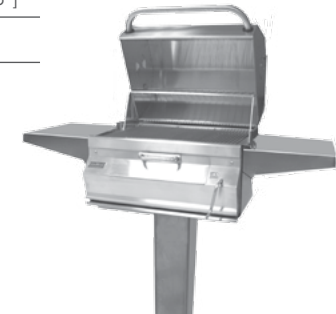

MODEL: 22-SC01C-G6 (pictured)
IN-GROUND POST

COOKING SURFACE 432 sq. inches [24" x 18"]

MODEL: 22-SC01C-P6
PATIO POST

COOKING SURFACE 432 sq. inches [24" x 18"]

*Cooking grids and ovens (if desired) for Firemaster & Lift-A-Fire Slide-In must be ordered separately.



ACCESSORIES

SIDE BURNERS, REFRIGERATION
& MORE

Echelon sideburners are designed as companion side cookers for the Echelon Diamond Grills. Featuring a contoured face, backlit control knobs, hot-surface ignition, and a power switch. All Echelon accessories plug in to the Echelon Diamond Grill transformer for power.



ECHELON POWER BURNER
MODEL: 19-4B2N-0
CUTOUT: 19" w x 18 3/4" d x 12" h

The Echelon Power Burner is the largest, most powerful side cooker available and provides the high heat that's perfect for wok cooking or frying a turkey! Offering a range of 3,000 to 60,000 BTU's. Available with porcelain cast iron or stainless steel grids.



ECHELON DBL SEARING STATION
MODEL: 32884-1
CUTOUT: 19" w x 18 3/4" d x 12" h

With the Echelon Double Searing Station, prepare restaurant-quality steaks. When steaks are flash-cooked up to 1200° using infrared technology, juices are locked in and meats are tender and full of flavor. With 34,000 BTU's.



ECHELON DBL SIDE BURNER
MODEL: 32814
CUTOUT: 11 1/2" w x 22 3/4" d x 12" h

Enjoy precise flame control on each burner to prepare side dishes and sauces for your meal (Two [2] 15,000 BTU's burners). Available with porcelain cast or stainless steel grids.



ECHELON SEARING STATION
MODEL: 32874-1
CUTOUT: 14" w x 22 3/4" d x 12" h

Sear favorites such as ahi tuna and marbled fillet mignon to perfection. 25,000 BTU's and up to 1000° of infrared heat.



ECHELON SIDE BURNER
MODEL: 32794-1
CUTOUT: 11 1/2" w x 14" d x 12" h

The Echelon Single Side Burner features a 15,000 BTU's burner, precise flame control valve, and stainless steel cover. Available with porcelain cast grid.

All Fire Magic® sideburners include stainless steel lid.

ACCESSORIES

SIDE BURNERS,
REFRIGERATION, & MORE



POWER BURNER
MODEL: 19-S0B1N-0
CUTOUT: 19" w x 18 ¾" d x 12" h

The Power Burner is the largest, most powerful side cooker available. It provides a range of BTU's from 3,000 to 60,000. Available with porcelain cast iron or stainless steel grids.



DOUBLE SEARING STATION
MODEL: 3288-1
CUTOUT: 19" w x 18 ¾" d x 12" h

With the Double Searing Station steaks are flash-cooked at 1200°, juices are locked in and meats are tender and full of flavor. With 34,000 BTU's of infrared heat, the double searing station is a welcome companion to your Fire Magic® grill.



SEARING STATION
MODEL: 3287-1
CUTOUT: 14" w x 22 ¾" d x 12" h

This single side burner flash cooks up to 25,000 BTU's and up to 1000° of infrared heat locking in juices for tender meat and full flavor. Perfect for an amazing seared steak.



DOUBLE SIDE BURNER
MODEL: 3281
CUTOUT: 11 ½" w x 22 ¾" d x 12" h

The Double side burner offers precise flame control on each burner to prepare side dishes and sauces for your meal (Two [2] 15,000 BTU's burners). Available with porcelain cast or stainless steel grids.



SINGLE SIDE BURNER
MODEL: 3279-1
CUTOUT: 11 ½" w x 14" d x 12" h

Features of this single side burner include a 15,000 BTU's burner, and precise flame control valve. Available with porcelain cast grid.



SIDE BURNER COUNTERTOP
MODEL: 3280
CUTOUT: 8 ¾" w x 14 ¼" d

Drops into the top of island. Features include 15,000 BTU's sealed burner, precise flame control valve, and stainless steel cover.

ACCESSORIES

SIDE BURNERS,
REFRIGERATION, & MORE



REFRIGERATOR
MODEL: 3590A
CUTOUT: 20" w x 21 1/4" d x 34 1/8" h

4.2 cubic foot. Interior light and, security lock and key. Reversible door hinge. When used outdoors, it must be installed in an enclosure.



PREMIUM REFRIGERATOR
MODEL: 3590-DR or DL
CUTOUT: 20" w x 21 1/4" d x 34 1/8" h

Custom-designed door is fabricated with a heavy-duty handle and radial corners for an exclusive look. Handy lock keeps contents safe. When used outdoors, it must be installed in an enclosure.



LARGE CAPACITY ICE MAKER
MODEL: 3593
CUTOUT: 16 3/4" w x 24 1/2" d x 34" h

Produces 44 lbs of ice in a 24 hr period and can store up to 25 lbs. UL listed for outdoor use and "Energy Star" rated. Continually producing ice on demand as ice is used. Suitable for outdoor and indoor applications.



REFRESHMENT CENTER
MODEL: 3596
CUTOUT: 25 1/2" w x 23 1/2" d x 12" h

Insulated walls, bottom drain, in-front shelving, attached bottle opener, dual sliding removable doors, included drain kit, and Echelon styled face.



TRASH CONTAINER
MODEL: 53825-T
CUTOUT: 12 3/4" w x 20" d x 24" h

Constructed of stainless steel with a hands-free foot lever, the door easily slides open to reveal a 10.5 gallon trash can. Fully enclosed.



PAPER TOWEL HOLDER
MODEL: 53812
CUTOUT: 12" w x 8" d x 9 1/4" h

Accepts and protects regular or jumbo rolls.



BAMBOO CUTTING BOARD
MODEL: 3582-1

This durable and functional Bamboo Cutting Board is perfect for preparing meats and vegetables for grilling. 12"x 14".



CUT & CLEAN COMBO
MODEL: 53816
CUTOUT: 16 3/4" w x 15 1/4" d x 15" h

Allows you to slice and dice on a Fire Magic® bamboo cutting board, then sweep debris right into the Fire Magic® trash receptacle or basic trash can via a deep stainless steel trash chute. Chute measures 14 3/4".



BAR CADDY
MODEL: 1D-S0
CUTOUT: 14 1/4" w x 22 1/4" d x 12" h

Bar Caddy comes equipped with a towel bar, bottle opener, sliding storage drawer, two stainless steel bottle sleeves and an installation hanger. Available with the optional steam warming accessory.



BLENDER W/ HOOD
MODEL: 3284A
CUTOUT: 8 3/4" w x 14 1/4" d

Fire Magic's® Blender is the perfect companion for any outdoor kitchen, bar caddy or beverage center. The attractive and sturdy stainless steel cover protects the 675-watt motor from the elements.



BUILT-IN BEVERAGE CENTER
MODEL: 1D-SSA
CUTOUT: 36 3/4" w x 23 1/2" d x 12" h

Features top storage shelf with rail, faucet with sink and drain, removable bamboo cutting board, storage drawer; wine glass holder; halogen lights, covered heavy-duty blender; insulated ice drawer, and 2 condiment holders. Also available in a portable unit and Diamond Series (1D-SSD).



GRIDDLE
MODEL: 3512A or 3513A

Griddle available for the Fire Magic® double side burner as well as the Echelon and Aurora grills. Perfect for breakfast, grilled or vegetables or fajitas.



SINK & FAUCET
MODEL: 3587 & 3588
CUTOUT: 14" w x 14" d x 17" h

Adds convenience and functionality to your outdoor kitchen. Purchase separately or together. Sink measures 15" x 15" x 6" and requires a 17" clearance underneath.



GRILL LIGHT
MODEL: 3574

This halogen 10 watt bulb makes evening grilling easy. When using the light on a grill without backburner, a light bracket must be ordered. Aurora Light Bracket: 3600-43, Legacy Light Bracket: 3600-18-SP, & AOG Light Bracket: 24-B-28



WOK
MODEL: 3572

Hard-anodized stick-resistant lined interior surface measures 14" in diameter.



GRILL BRUSH
MODEL: 3576-1

The brass bristles on Fire Magic's® Grill Brush make clean up fast and easy. Includes one replacement brush head. Replacement brush heads also available.



DISPOSABLE DRIP TRAY LINER
MODEL: 3557 (4-PACK)

Custom-designed for Fire Magic® grills and sold in packs of 4, these convenient disposable drip tray liners reduce the risk of grease fires.



STAINLESS STEEL CLEANER
MODEL: 3581-6 (6-Pack)

Protect your investment with the Fire Magic® Stainless Steel Cleaner. Takes only a small amount to cut through grease and food build up. Removes most heat stains and rust spots.

ACCESSORIES

SIDE BURNERS,
REFRIGERATION, & MORE



CHARCOAL BASKET
MODEL: 3562-1 (13"x 10")
MODEL: 3562-2 (16"x 10")

Cooking with wood chunks or charcoal is easier than ever. Basket sits on top of the burner, gas burners ignite the chunks or coals. Bottom tray catches ashes for easy clean-up.



CHICKEN HOLDER
MODEL: 3617E

Enjoy a golden, succulent chicken the quick and easy way!



TURKEY HOLDER
MODEL: 3615E

This sturdy holder is also perfect for beef, pork and lamb roasts.



TURKEY FRYER KIT
MODEL: 3570

You'll be amazed at how tender a deep-fried turkey can be. Kit includes pot, inner basket with sturdy handle and thermometer probe. Great as a crab or corn pot.

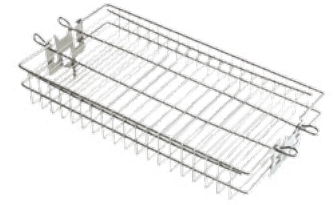

ROTISSERIE BASKET
MODEL: 3618

A versatile, stainless steel basket for skewers, burgers, ribs or fish.



FOUR-PIECE TOOL SET
MODEL: 3575

Includes a fork, spatula, knife and tongs. Constructed of quality stainless steel.



STRAIGHT LINE GAS VALVE
MODEL: AV-30

Can be attached to gas line for additional safety.



SAFETY TIMER
MODEL: 3090 (3 hr timer)
MODEL: 3092 (1 hr timer)

Fire Magic's® 3 Hour, and 1 Hour, Safety Timers offers additional safety and automatically shuts off gas flow at pre-set times. Easy to install. Great for apartment and condominium use.



VENT HOOD
MODELS: 36-VH-6, 42-VH-6,
48-VH-6, 60-VH-6

Dual 120v halogen lights, 1200 CFM variable speed blower, 30" extra deep design and anodized aluminum removable filters for easy cleaning.



GRILL COVERS
MODELS: Various "E" Styles

Custom fitted to Fire Magic® grills and accessories, these rip stop fabric covers look great and are double stitched for durability.



ISLAND SYSTEMS

GLASS FIBER REINFORCED
CONCRETE ISLAND SYSTEMS

ISLAND SYSTEMS

Constructed from durable Glass Fiber Reinforced Concrete (GFRC) and easily assembled on site, these Island Systems are designed specifically for Fire Magic® equipment and make a stunning statement. Café Blanco island bases with contrasting polished GFRC Smoke counter tops provide a handsome concrete look.



MODEL: DC790-CBR-108SM

DIMENSIONS 107 ½" w x 34 ¾" d x 35 ¼" h



MODEL: DC430-CBR-75SM

DIMENSIONS 76" w x 34 ¾" d x 35 ¼" h



DOORS & DRAWERS

FLUSH MOUNTED, PREMIUM,
SELECT, & LEGACY



FLUSH MOUNTED
MODEL: 53920-SL

FLUSH MOUNTED

MOUNTED DOORS AND DRAWERS (5 Series)

Featuring heavy-duty handles with cast stainless steel mounts, these doors and drawers are designed to close flush with the frame using a strong magnetic latch. Flush Mounted Doors and Drawers are filled with polyurethane foam for insulation and a solid feel. A continuous rain guard protects from water getting into your custom enclosure. Available in a variation of door and drawer configurations and sizes. With so many options there is a combination available to meet any outdoor kitchen storage need.



PREMIUM
MODEL: 43920-SL

PREMIUM

DOORS AND DRAWERS (4 Series)

Stylized with rounded edges to match the contours of your Fire Magic® Grill, these doors and drawers feature heavy-duty handles with cast stainless steel mounts and are mounted outside the frame. A strong magnetic latch ensures secure closure and polyurethane foam filling gives a solid feel and insulation. A continuous rain guard protects from water getting into your custom enclosure. Available in a large variety of door and drawer configurations and sizes.



SELECT
MODEL: 33920-SL

SELECT

DOORS AND DRAWERS (3 Series)

These doors and drawers feature outside mounting, double wall and square edge construction, a slim tubular stainless steel handle and heavy-duty magnetic latch. A continuous rain guard protects from water getting into your custom enclosure. Available in a large variety of door and drawer configurations and styles.



LEGACY
MODEL: 23920-S

LEGACY

DOORS AND DRAWERS (2 Series)

Outside mounted with angled edges, the Legacy Doors and Drawers feature a slam latch for secure closure. Available in 12 door and 4 drawer configurations and sizes. Select styles available with black powder-coated finish. The Legacy doors and drawers are the most economical for builders and homeowners alike.

DOORS & DRAWERS

FLUSH MOUNTED



DBL DOORS W/ DUAL DRAWERS
MODEL: 53930S-22
CUT-OUT: 21" h x 30 1/2" w x 20 1/2" d



SINGLE ACCESS DOOR
MODEL: 53920-SL or SR
CUT-OUT: 21" h x 14 1/2" w



SINGLE ACCESS DOOR
MODEL: 53924-SL or SR
CUT-OUT: 25" h x 17 1/2" w



SINGLE DOOR W/ DUAL DRAWERS
MODEL: 53820-SR or SL
CUT-OUT: 21" h x 14 1/2" w x 20 1/2" d
Available w/ Louvers (-TSR or -TSL)



SINGLE ACCESS DOOR
MODEL: 53917-SR or SL
CUT-OUT: 18" h x 24 1/2" w



SINGLE ACCESS DOOR
MODEL: 53914-SR or SL
CUT-OUT: 15" h x 20 1/2" w



DOUBLE ACCESS DOOR
MODEL: 53930S
CUT-OUT: 21" h x 30" w



DOUBLE ACCESS DOORS
MODEL: 53934S
CUT-OUT: 15" h x 30" w



TRIPLE DRAWER
MODEL: 53803
CUT-OUT: 26 1/4" h x 14 1/2" w x 20 1/2" d



DOUBLE DRAWER
MODEL: 53802
CUT-OUT: 15 3/4" h x 14 1/2" w x 20 1/2" d



SINGLE DRAWER
MODEL: 53801
CUT-OUT: 5 1/4" h x 14 1/2" w x 20 1/2" d



DBL DOORS W/ TRASH & DUAL DRAWERS
MODEL: 53930S-12
CUT-OUT: 21" h x 30 1/2" w x 20 1/2" d
Available w/ Louvers (-12T) for propane tank



ELECTRIC WARMING DRAWER†
MODEL: 53830-SW
CUT-OUT: 14 1/2" h x 32 1/4" w x 22" d



MASONRY DRAWER
MODEL: 53830-S
CUT-OUT: 14 1/2" h x 32 1/4" w x 22" d



DOUBLE ACCESS DOORS
MODEL: 53938S
CUT-OUT: 16" h x 39" w

† Buffet Warming Accessory available. Model No: 23830-SW-CD



**DBL DOORS W/TANK TRAY, LOUVERS,
& DUAL DRAWERS**
MODEL: 43930S-12T
CUT-OUT: 21" h x 30 1/2" w x 20 1/2" d



SINGLE DOOR W/ DUAL DRAWERS
MODEL: 43820-SL or SR
CUT-OUT: 21" h x 14 1/2" w x 20 1/2" d



SINGLE ACCESS DOOR
MODEL: 43920-SR or SL
CUT-OUT: 21" h x 14 1/2" w

**DOORS &
DRAWERS**

PREMIUM



**SINGLE ACCESS DOOR W/ TANK TRAY
& LOUVERS**
MODEL: 43820-TSL or TSR
CUT-OUT: 21" h x 14 1/2" w x 20 1/2" d



SINGLE ACCESS DOOR
MODEL: 43917-SR or SL
CUT-OUT: 18" h x 24 1/2" w



SINGLE ACCESS DOOR
MODEL: 43914-SR or SL
CUT-OUT: 15" h x 20 1/2" w



DOUBLE ACCESS DOORS
MODEL: 43930S
CUT-OUT: 21" h x 30" w



**DOUBLE DOORS W/ TRASH TRAY &
DUAL DRAWERS**
MODEL: 43930S-12
CUT-OUT: 21" h x 30 1/2" w x 20 1/2" d



TRIPLE DRAWER
MODEL: 43803
CUT-OUT: 26 1/4" h x 14 1/2" w x 20 1/2" d



DOUBLE DRAWER
MODEL: 43802
CUT-OUT: 15 3/4" h x 14 1/2" w x 20 1/2" d



SINGLE DRAWER
MODEL: 43801
CUT-OUT: 5 1/4" h x 14 1/2" w x 20 1/2" d



DOUBLE DOORS W/ 2 DUAL DRAWERS
MODEL: 43930S-22
CUT-OUT: 21" h x 30 1/2" w x 20 1/2" d



ELECTRIC WARMING DRAWER†
MODEL: 43830-SW
CUT-OUT: 13" h x 31" w x 20 1/2" d



MASONRY DRAWER
MODEL: 43830-S
CUT-OUT: 13" h x 31" w x 20 1/2" d



DOUBLE ACCESS DOORS
MODEL: 43934S
CUT-OUT: 15" h x 30" w

† Buffet Warming Accessory available. Model No: 23830-SW-CD

DOORS & DRAWERS

SELECT



ELECTRIC WARMING DRAWER†
MODEL: 33830-SW
CUT-OUT: 13" h x 31" w x 20 1/2" d



MASONRY DRAWER
MODEL: 33830-S
CUT-OUT: 13" h x 31" w x 20 1/2" d



DOUBLE DOORS W/ TANK TRAY, LOUVERS, AND DUAL DRAWERS
MODEL: 33930S-12T
CUT-OUT: 21" h x 30 1/2" w x 20 1/2" d
Available w/o Louvers (-12) for trash receptacle



SINGLE ACCESS DOOR
MODEL: 33924-SR or SL
CUT-OUT: 25" h x 17 1/2" w



TRIPLE DRAWER
MODEL: 33803
CUT-OUT: 26 1/4" h x 14 1/2" w x 20 1/2" d



DOUBLE DRAWER
MODEL: 33802
CUT-OUT: 15 3/4" h x 14 1/2" w x 20 1/2" d



SINGLE DRAWER
MODEL: 33801
CUT-OUT: 5 3/4" h x 14 1/2" w x 20 1/2" d



DOUBLE DOORS W/ 2 DUAL DRAWERS
MODEL: 33930S-22
CUT-OUT: 21" h x 30 1/2" w x 20 1/2" d



SINGLE ACCESS DOOR W/ TANK TRAY & LOUVERS
MODEL: 33820-TSL or TSR
CUT-OUT: 21" h x 14 1/2" w x 20 1/2" d



SINGLE ACCESS DOOR
MODEL: 33914-SR or SL
CUT-OUT: 15" h x 20 1/2" w



SINGLE ACCESS DOOR
MODEL: 33920-SR or SL
CUT-OUT: 21" h x 14 1/2" w



DOUBLE ACCESS DOOR
MODEL: 33930S
CUT-OUT: 21" h x 30" w



SINGLE ACCESS DOOR
MODEL: 33917-SR or SL
CUT-OUT: 18" h x 24 1/2" w



SINGLE DOOR W/ DUAL DRAWERS*
MODEL: 33820-SR or SL
CUT-OUT: 21" x 14 1/2" x 20 1/2"

† Buffet Warming Accessory available. Model No: 23830-SW-CD



SINGLE DOOR W/
DUAL DRAWERS
MODEL: 23820-S
CUT-OUT: 20 ½"h x 14 ½"w x 20 ½"d



MASONRY DRAWER
MODEL: 23830-S
CUT-OUT: 13"h x 31"w x 20 ½"d



SINGLE ACCESS DOOR 
MODEL: 23917-S
CUT-OUT: 17 ½"h x 24 ½"w

DOORS &
DRAWERS

LEGACY



DRAWER W/ PROPANE DOOR ASSY
MODEL: 25914-S
CUT-OUT: 27 ¾"h x 14 ½"w x 20 ½"d



SINGLE ACCESS DOOR W/ LOUVERS
MODEL: 23920-1-S
CUT-OUT: 20 ½"h x 14 ½"w



DOUBLE ACCESS DOOR
MODEL: 23930-S
CUT-OUT: 20 ½"h x 30"w



SINGLE ACCESS DOOR W/
TANK TRAY & LOUVERS
MODEL: 23920-1T-S
CUT-OUT: 20 ½"h x 14 ½"w x 20 ½"d



SINGLE ACCESS DOOR 
MODEL: 23920-S
CUT-OUT: 20 ½"h x 14 ½"w



DOUBLE DOORS W/ DUAL DRAWERS
& TRASH TRAY
MODEL: 23930S-12
CUT-OUT: 21"h x 30 ½"w x 20 ½"d



VENTING PANEL LOUVERED
STAINLESS STEEL
MODEL: 5510-01
CUT-OUT: 3 ¾"h x 12 ¾"w

Also available: (not shown)
SINGLE ACCESS DOORS 

- | | |
|----------------|------------------------|
| MODEL: 23912-S | CUT-OUT: 12 ½" x 18 ½" |
| MODEL: 23918-S | CUT-OUT: 18 ½" x 12 ½" |
| MODEL: 23924-S | CUT-OUT: 24 ½" x 17 ½" |
| MODEL: 23914-S | CUT-OUT: 14 ½" x 20 ½" |



14724 PROCTOR AVE. CITY OF INDUSTRY, CA 91746
 WWW.FIREMAGICGRILLS.COM



FIRE MAGIC® OUTDOOR GAS GRILL WARRANTY HIGHLIGHTS*

CRAFTED WITH PRIDE IN THE USA AND CONSTRUCTED ENTIRELY OF 304 STAINLESS STEEL, FIRE MAGIC® HAS BEEN MANUFACTURING THE FINEST OUTDOOR GRILLS YOU CAN BUY FOR OVER 75 YEARS. OUR WARRANTY COVERAGE REFLECTS THE QUALITY MATERIALS AND CRAFTSMANSHIP FOUND IN ALL FIRE MAGIC® GRILLS. WHEN INVESTING IN A GRILL, CONSIDER THE ASSURANCE PROVIDED BY THE FIRE MAGIC® WARRANTY:

- Fire Magic® pays for first year warranty labor allowance
- Fire Magic® pays for shipping warranted replacement parts
- Fire Magic® pays for shipping warranted defective parts back to the factory
- Fire Magic's® qualified technical service representatives are available 10 hours a day, 5 days a week to assist with questions, installation and service

You will find the Fire Magic® warranty to be the best and most comprehensive in the industry.

LIFETIME WARRANTY

CAST STAINLESS STEEL BURNERS, STAINLESS STEEL ROD COOKING GRIDS AND GAS GRILL HOUSINGS

TWENTY YEAR WARRANTY STAINLESS STEEL TUBULAR BURNERS

FIFTEEN YEAR WARRANTY BRASS VALVES, INNER LINERS, MANIFOLD ASSEMBLIES AND BACK BURNER ASSEMBLIES

TEN YEAR WARRANTY FIRE MAGIC® STAINLESS STEEL ROD COOKING GRIDS AND STAINLESS STEEL HOUSING ON ELECTRIC GRILLS

FIVE YEAR WARRANTY INFRARED BURNERS, FLAVOR GRIDS AND CHARCOAL STAINLESS STEEL GRILLS AND SMOKERS

THREE YEAR WARRANTY SIDE BURNERS AND ALL OTHER FIRE MAGIC GAS GRILL COMPONENTS

ONE YEAR WARRANTY IGNITION SYSTEMS, ELECTRONIC COMPONENTS, GRILL ACCESSORIES AND CHARCOAL GRILL COMPONENTS

**See full warranty for complete details.*

All cut-out dimensions are for reference purpose only. Specifications are subject to change. Please refer to your instruction manual for the most up to date measurements.